

Grillo

AGRIGARDEN MACHINES

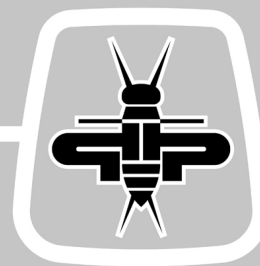

STANDARD CONFIGURATION
WITH 58 cm ALL PURPOSE FLAIL MOWER

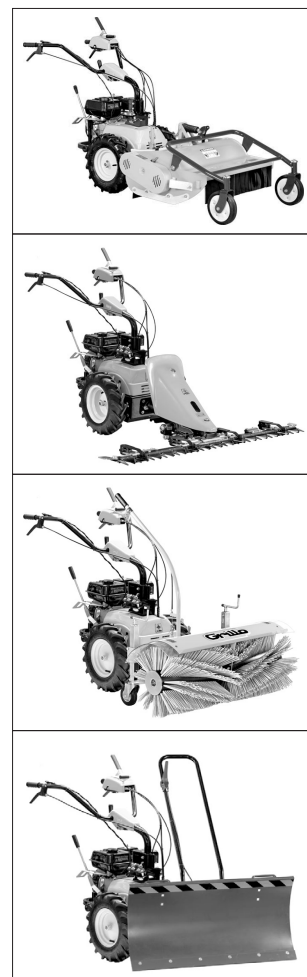

GH 8 AGM Hydrostatic Multi-tool

OPERATOR'S MANUAL

EN



02601.2026.02

TABLE OF CONTENTS

1. Introduction	3	15. Troubleshooting guide.....	19
2. Description and intended use	3	16. Maintenance schedule.....	20
3. Use and safety decals.....	4	17. Lubrication chart.....	20
4. General safety rules	5	18. Storage and prolonged inactivity	21
5. General warnings to keep in mind.....	7	19. Available attachments.....	21
6. Identification of machine controls and functions	8	20. Technical assistance service	22
7. Identification of machine components.....	9	20.1 Assistance	22
8. Technical specifications	10	20.2 Identification data	22
9. Operating instructions - GH 8 AGM standard configuration with 58 cm flail mower	11	20.3 Spare parts	22
9.1 Setting up the machine for use	11	20.4 Warranty	22
9.2 Checks to be carried out before starting the engine	11	20.5 How to order spare parts	22
9.3 Starting the engine	11	21. Transport warnings	22
9.4 Starting the machine.....	11	22. Disposal	22
9.5 Work conclusion	12	Declaration of Conformity	23
9.6 Ordinary machine cleaning.....	12		
9.7 Useful rules for correct use.....	13		
9.8 Sloping terrain	13		
10. Safety devices	13		
10.1 Active coupling	13		
10.2 Stationary brake	13		
11. Ordinary adjustments	14		
11.1 Handlebar setting	14		
11.2 Cutting height adjustment.....	14		
12. Extraordinary adjustments.....	14		
12.1 Adjusting the turn levers	14		
12.2 Adjusting the forward lever	15		
12.3 Adjusting the PTO lever.....	15		
12.4 Adjusting the handlebar rotation lever	15		
12.5 Adjusting the flail mower belt tension	15		
13. Ordinary maintenance	16		
13.1 Engine maintenance.....	16		
13.2 Maintenance of the flail mower.....	16		
14. Extraordinary maintenance	17		
14.1 Maintenance of the hydrostatic axle	17		
14.2 Replacing the hydrostatic axle belt	18		
14.3 Replacing the PTO belts.....	18		
14.4 Replacing the flail mower drive belt.....	18		

Translation of the original manual.
All information, illustrations and technical specifications in this manual are based on the latest information available at the time of publication.
Subject to change without prior notice.

1. INTRODUCTION

Dear Customer,

we thank you for the trust and preference you have placed in our Grillo GH 8 AGM all purpose flail mower and we are confident that the use of your new machine will fully meet your requirements.

For optimal use and maintenance over time, please carefully read and follow the instructions in this booklet; this will enable you to obtain the best results and safeguard your purchase.

Please keep this manual, which should always accompany the machine as an integral part of it.

Reading the operator's manual is very important.

2. DESCRIPTION AND INTENDED USE

The GH 8 AGM is a hydrostatic multi-tool, a self-propelled agricultural machine equipped in the standard version with a 58 cm flail mower for cutting grass in rustic areas even on sloping surfaces (max 20°).

The machine consists of a supporting frame, on which is installed an internal combustion engine that drives the wheels and a PTO where the attachment (in the standard version a 58 cm flail mower) is connected. Attachments such as a 68 cm all purpose flail mower, 132 cm pro double blade cutter bar, 100 cm sweeper, 100 cm snow blade can be attached.

The machine is controlled by an operator on the ground who follows its movement by guiding it via a handlebar, on which the controls are located.

Any other use is considered as improper use.

This machine must only be used by personnel who are familiar with its specific features, safety regulations and all that concerns accident prevention.

Any improper use of the machine will invalidate the warranty and relieve the manufacturer of all responsibility; any risk resulting from improper use will be borne by the user.

Maintenance and repair of the machine must be carried out by qualified personnel following the procedures specified by the manufacturer. Any alteration or tampering will invalidate the warranty and relieve the manufacturer of all responsibility for damage or accidents.

MARKINGS IN THE MANUAL

This manual contains warnings highlighted in bold and marked with these symbols:



This symbol and the text that follows it contain information that highlights possible, even very serious, risks to the safety of the operator and anyone working on the machine if they do not consider the written information and procedures.



This heading informs the operator of actions or conditions that could damage the machine.

Read these messages carefully to avoid injury or damage to the machine.

The retailer is responsible for inspecting the machine before delivery and for completing the inspection form "PRE-DELIVERY INSPECTION".

On this occasion the retailer will provide the customer with all the information necessary to use the machine.

The customer will receive the machine in optimum condition.

3. USE AND SAFETY DECALS

Forward lever and PTO engagement

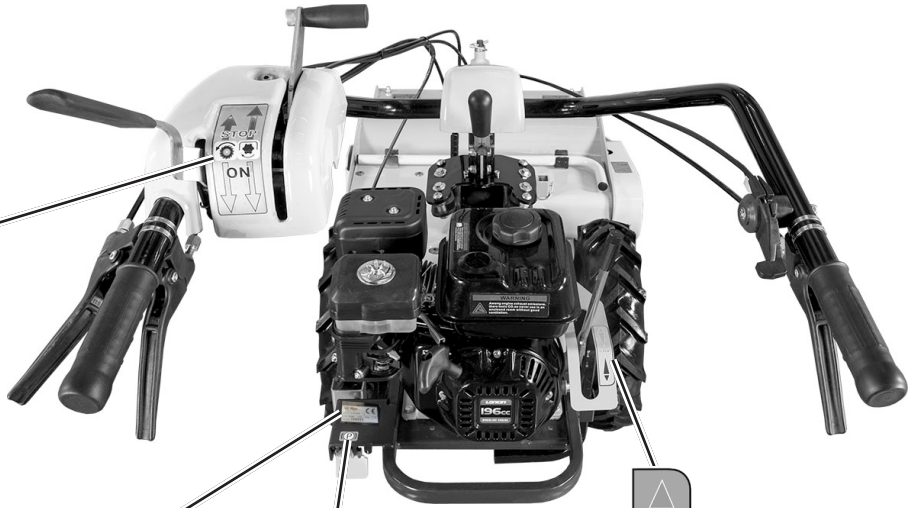

Serial number



Parking brake



Forward gear

STOP position

Reverse gear

Danger - disconnect the spark plug before doing any maintenance

Consult the manual

Fire hazard



Danger of gas inhalation

Danger of burns

Danger of bursting

Danger - sharp parts

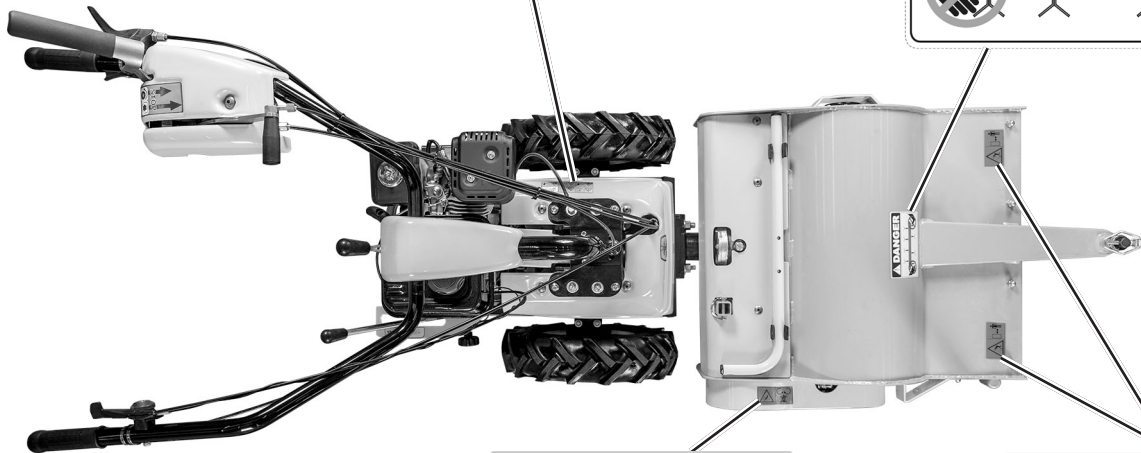
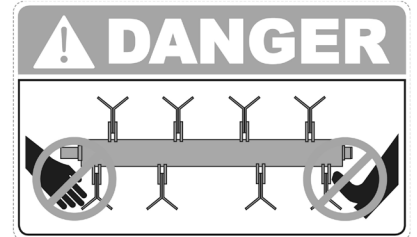

Danger - transmission parts



Danger - thrown objects, keep a safe distance



4. GENERAL SAFETY RULES

ACCIDENT PREVENTION RULES

On the machine and in this manual there are warnings and indications accompanied by this symbol:



it indicates the presence of a potential hazard for which particular caution should be taken for your own safety and for the safety of others who may be within the operating range of the machine.

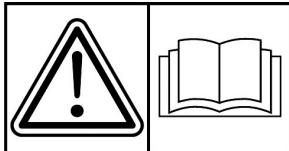

All accident prevention rules in this manual are important and must be observed. Always keep the manual handy and read it carefully to learn how to use the machine safely. Do not allow anyone to use the machine without having received comprehensive instructions.

EXPLANATION OF WARNING DECALS

Risk of injury

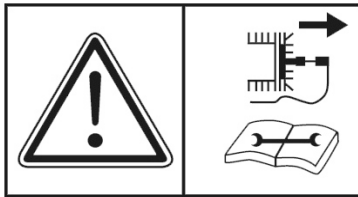

Before doing any maintenance, disconnect the spark plug and read the instruction manual.

Danger of bursting

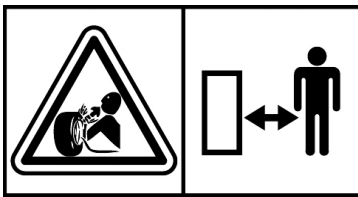

Rim separation or tyre bursting can cause serious injury or even death. Be sure to maintain tyre pressure at the level recommended in this manual, excessive pressure can cause the tyre to burst.

If a tyre is damaged or cut, do not use it, it could burst. To replace or repair it, contact a specialised centre.

Danger of burns



Take particular care not to come into contact with hot engine parts.

Danger of gas inhalation



Exhaust fumes can cause serious damage to health or death. If it is necessary to start the engine in an enclosed space, use an extension piece to the exhaust pipe to blow out the smoke. Work in a well ventilated area.

Danger of fire



Handle fuel with care as it is highly flammable; do not refuel while smoking, near open flames or sparks, when the engine is running.

Danger of injury from sharp knives

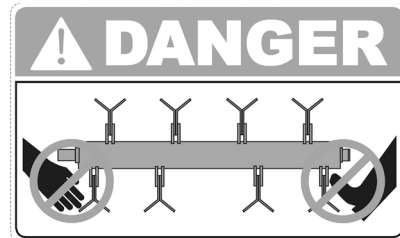

Do not put hands or feet under the all purpose flail mower when the engine is running.

Danger of thrown objects, keep a safe distance



Do not work with the all purpose flail mower on gravel or foreign bodies that can be thrown at a distance and be very dangerous. Keep people at least 15 m away when the machine is running.

Risk of injury caused by transmission parts



When the engine is running, never touch pulleys or belts, do not carry out maintenance and keep hands away from the indicated area. Do not remove the hood with the engine running.

PERSONAL PROTECTION EQUIPMENT



Before using the machine the appropriate personal protection equipment must be worn: body protection, protective gloves, safety footwear, hearing protection, goggles.

5. GENERAL WARNINGS TO KEEP IN MIND

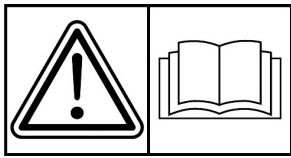

WARNING: Read carefully before operating the machine.

Caution is the main requirement in accident prevention! Carefully read the following warnings when using the machine, even before starting work. Improper use can be dangerous. Observe the following precautions:

- Read this manual completely before starting and running the machine;
- Before handing the machine over to other people, make them aware of the safety rules and how to use the machine;
- Pay particular attention to the safety decals on the machine;
- When working with the all purpose flail mower (or other optional attachments) always wear appropriate work clothes, long trousers, gloves, safety footwear, goggles; avoid wearing clothing or accessories that can get caught in the controls or in the flail mower (e.g. loose trousers, scarves, etc.);
- The use of hearing protection equipment is recommended when using the machine continuously. Use earplugs or earmuffs that comply with current regulations.

SAFETY IN THE WORKING ENVIRONMENT

- Before switching on the machine, check that there are no animals or people nearby, especially children; the minimum distance is 15 m;
- Check the area where the machine is to be used: before starting work, remove all objects that could damage the knives or that could be thrown from the rotating tool (e.g. stones);
- Take care when working near a road, when there are passers-by;
- Do not work near ditches or embankments that may collapse under the weight of the machine, especially if the surface is uneven or wet;
- Be particularly careful when working on slopes, take special care when changing direction, do not work on excessively steep slopes (max 20°). The machine's manoeuvrability is reduced on slopes;
- Be very careful when reversing, in case of danger let go of the handlebar, the machine will stop immediately;
- It is dangerous to operate the levers sharply with the engine at maximum speed;
- To avoid toxic exhaust fumes, do not use the machine in enclosed spaces.

DRIVING AND BEHAVIOURAL SAFETY

- Do not use the machine to transport people or animals;
- Children under 16 years of age must not use the machine;
- Do not use the machine when fatigued or under the influence of alcohol, drugs or medications that impair the operator's physical and cognitive abilities;
- On uneven terrain proceed at low speed;
- Only work in sunlight or with good artificial light;
- Do not leave the machine on a slope;
- The machine must only ever be accompanied by walking, never by running.

FURTHER SAFETY MEASURES

- If you hit a foreign body, disengage the attachment, switch off the engine, and inspect the rotor and blades for damage;
- If the machine begins to vibrate abnormally after a knock, immediately carry out a general check to identify the reason for the anomaly. If necessary, request the assistance of an authorised Grillo workshop;
- Rotation of the flail mower rotor is very dangerous, never put your hands or feet near the rotor while the engine is running;
- The guards installed on the machine (bonnets, plastics, etc.) must not be removed when working;
- Before starting work, check that all safety devices are in working order. Do not tamper with or deactivate them;
- Do not operate the machine barefoot; keep feet well clear of the rotor;
- Before checking, adjusting, repairing or simply cleaning the machine, switch off the engine;
- Do not change the engine settings, especially the maximum revs;
- Do not have anyone check the machine while you are driving with the engine running.

FUEL AND FIRE HAZARD

- Only refuel outdoors, always switch off the engine, stay away from sparks or flames, do not smoke! Securely replace tank and fuel container caps;
- Avoid fuel spills. After filling the tank clean up any spillage on the machine before starting the engine;
- Store fuel in containers specifically designed for this purpose;
- If it is necessary to empty the tank, do so outdoors or in a ventilated area;
- Caution! To reduce the risk of fire, always keep the engine, muffler, exhaust manifold, fuel tank area and fuel line clean and free of grass, leaves and dust;
- Do not store the machine in buildings where the fuel vapours could reach flames and sparks;
- **Allow the engine to cool down before storing the machine in an enclosed area.**

SAFE REPLACEMENTS

- Deformed or damaged flail mower knives must always be replaced, never repaired;
- Always use genuine Grillo spare parts and accessories;
- Grillo machines are designed for the use of genuine Grillo accessories or accessories from authorised manufacturers. Do not install non-genuine accessories, accessories from unauthorised manufacturers, or accessories modified by unauthorised personnel on your machine.

6. IDENTIFICATION OF MACHINE CONTROLS AND FUNCTIONS

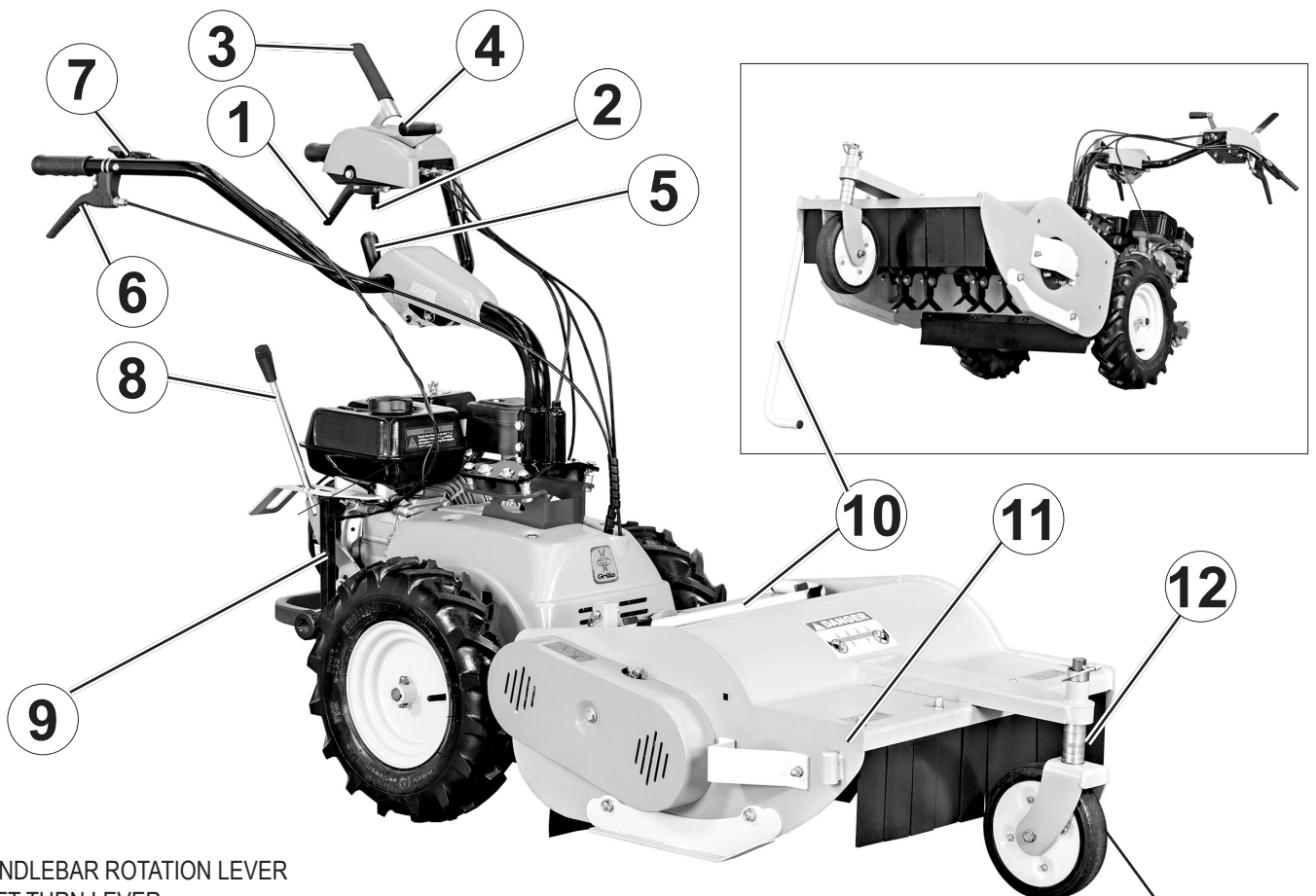
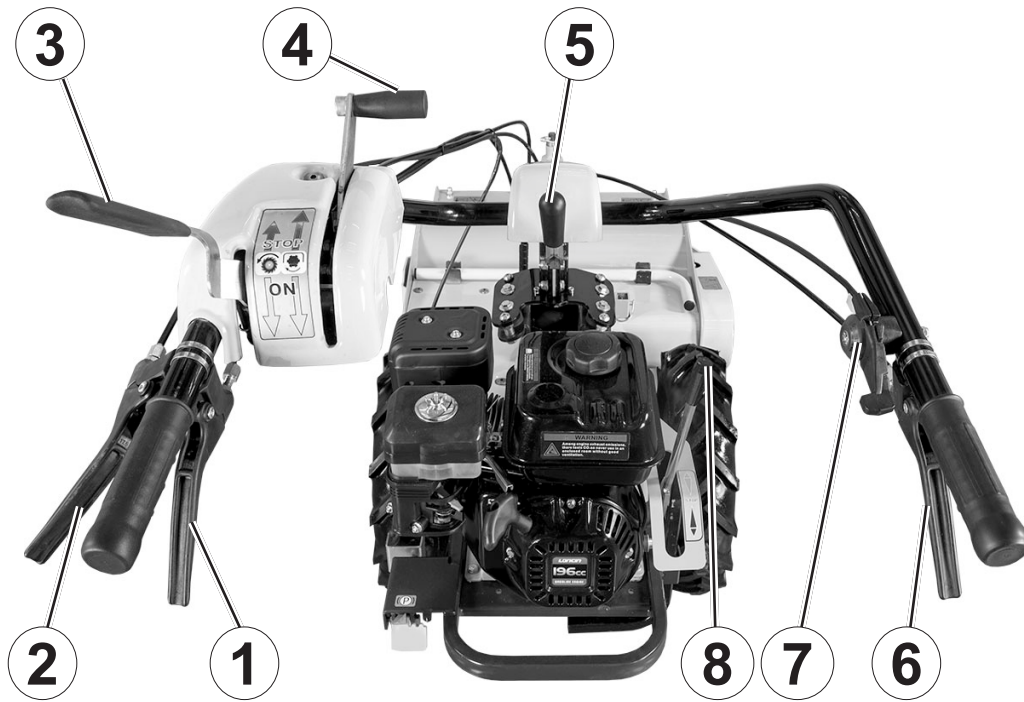

1. HANDLEBAR ROTATION LEVER
2. LEFT TURN LEVER
3. FORWARD LEVER
4. PTO LEVER
5. HANDLEBAR HEIGHT ADJUSTMENT LEVER
6. RIGHT TURN LEVER
7. THROTTLE
8. SPEED CONTROL LEVER
9. MACHINE BODY SUPPORT ROD
10. FLAIL MOWER LIFTING ROD
11. LIFTING ROD HOLDER
12. FLAIL MOWER CUTTING HEIGHT ADJUSTMENT SPACERS

7. IDENTIFICATION OF MACHINE COMPONENTS

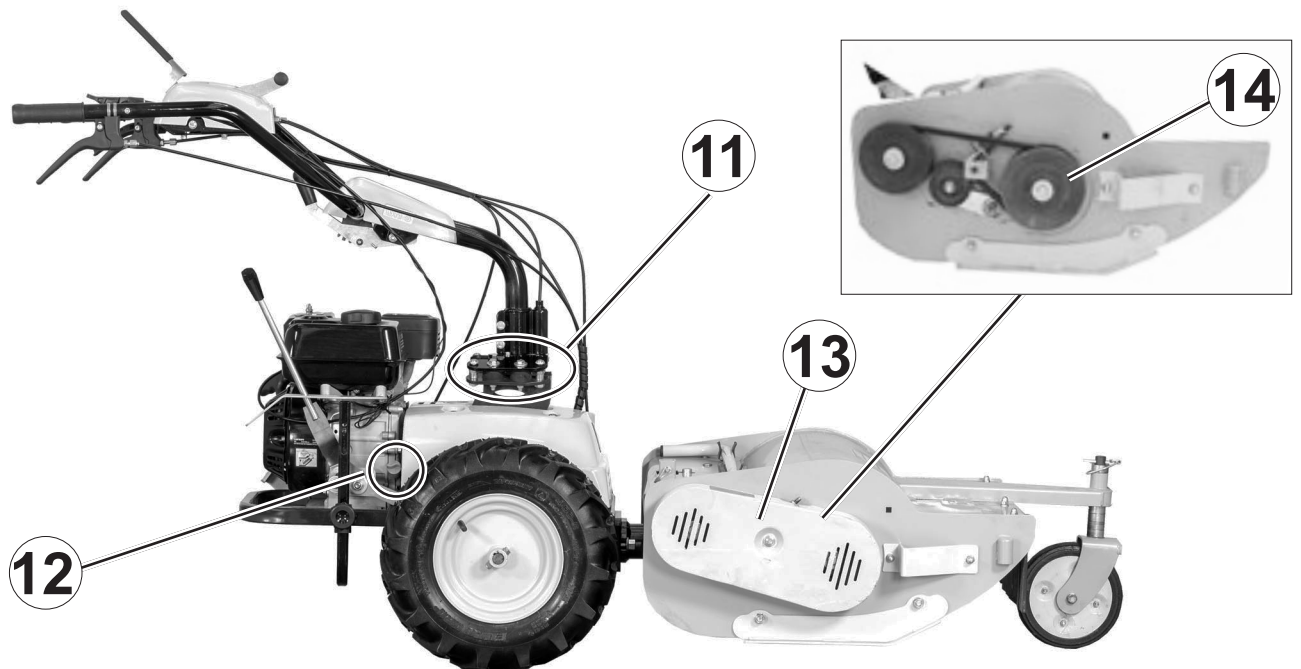
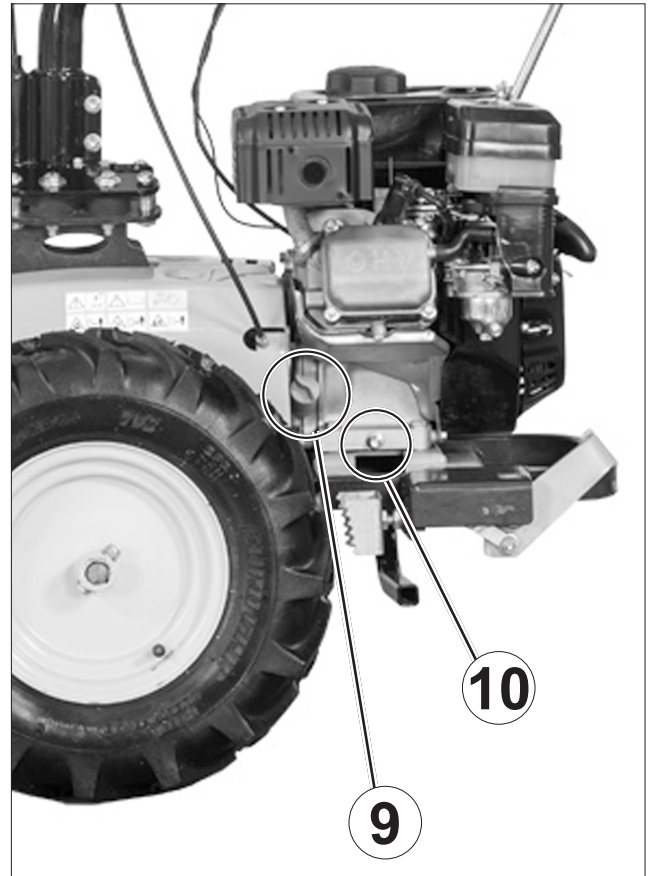
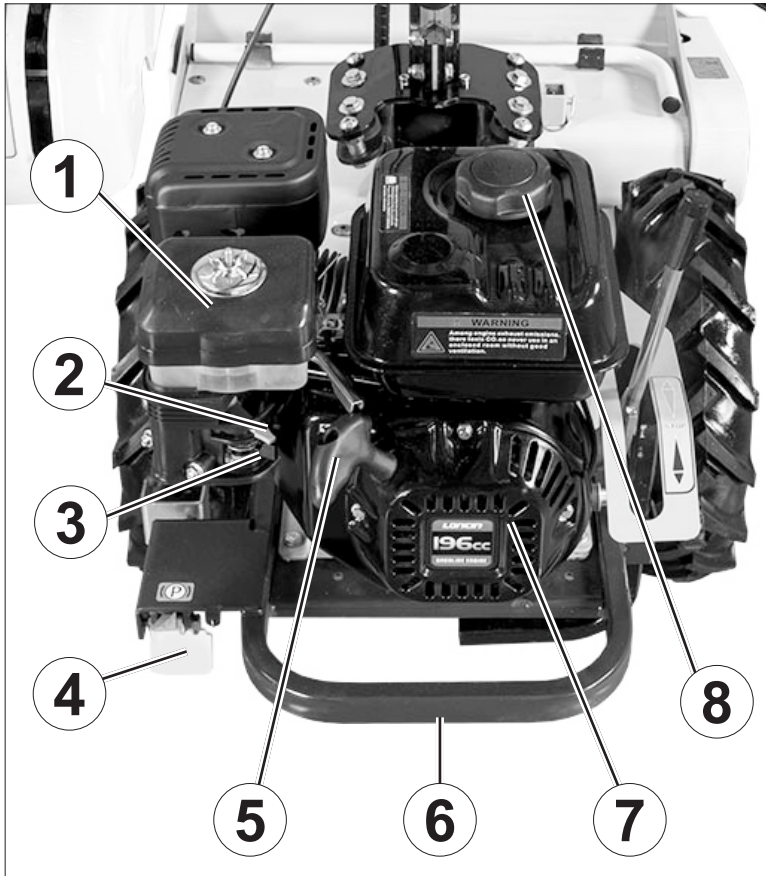

1. ENGINE AIR FILTER
2. CHOKE LEVER
3. FUEL TAP
4. PARKING BRAKE PEDAL
5. RECOIL KNOB
6. ENGINE GUARD
7. ENGINE FAN GRID
8. FUEL TANK CAP
9. LEFT-HAND ENGINE OIL LEVEL AND TOP-UP PLUG
10. ENGINE OIL DRAIN PLUG
11. HANDLEBAR DAMPER
12. RIGHT-HAND ENGINE OIL LEVEL AND TOP-UP PLUG
13. PROTECTIVE GUARD
14. FLAIL TRANSMISSION AND BELT

8. TECHNICAL SPECIFICATIONS

MODEL: GH 8 AGM Multi-tool, standard configuration with 58 cm all purpose flail mower.

ENGINE: Loncin G210 FA, 212 cm³, 4.4 kW (6 HP) at 3600 rpm, single-cylinder petrol engine.

FUEL TANK CAPACITY: 3 litres

STARTER: breakaway with recoil starter.

TRANSMISSION: hydrostatic.

SPEED: 0 to 6 km/h continuously variable, reverse gear 0 to 3 km/h.

DRIVING SYSTEM: lever steering with traction disengagement on the wheel axle.

HANDLEBAR: adjustable in height and sideways, foldable.

DRIVING WHEELS: with 4.00-8 tyres.

FRONT WHEEL (all purpose flail mower attachment): solid and puncture-proof.

SAFETY DEVICE: active coupling (immediate stop of the attachment when the lever is released).

PARKING BRAKE: pedal-operated.

PTO: at 965 rpm anticlockwise.

CUTTING SYSTEM: rotor with Y-shaped knives.

FLAIL ROTOR SPEED: 2400 rpm

FLAIL ROTOR DIAMETER: 29.5 cm

CUTTING WIDTH: 58 cm

CUTTING HEIGHT: adjustable from 2 to 11 cm by shifting the spacers provided (58 cm all purpose flail mower).

DIMENSIONS (complete with 58 cm all purpose flail mower)

- Max handlebar width (A): 70 cm
- Flail mower width (B): 69 cm
- Width at the wheels (C): 60 cm
- Machine body length (D): 106 cm
- Total length (E): 200 cm
- Height (F): 97 cm

WEIGHT (complete with 58 cm all purpose flail mower): 135 kg

WEIGHT (machine body only): 75 kg

AVAILABLE ATTACHMENTS:

- 68 cm all purpose flail mower;
- 132 cm pro double blade cutter bar;
- 100 cm sweeper;
- 100 cm snow blade.

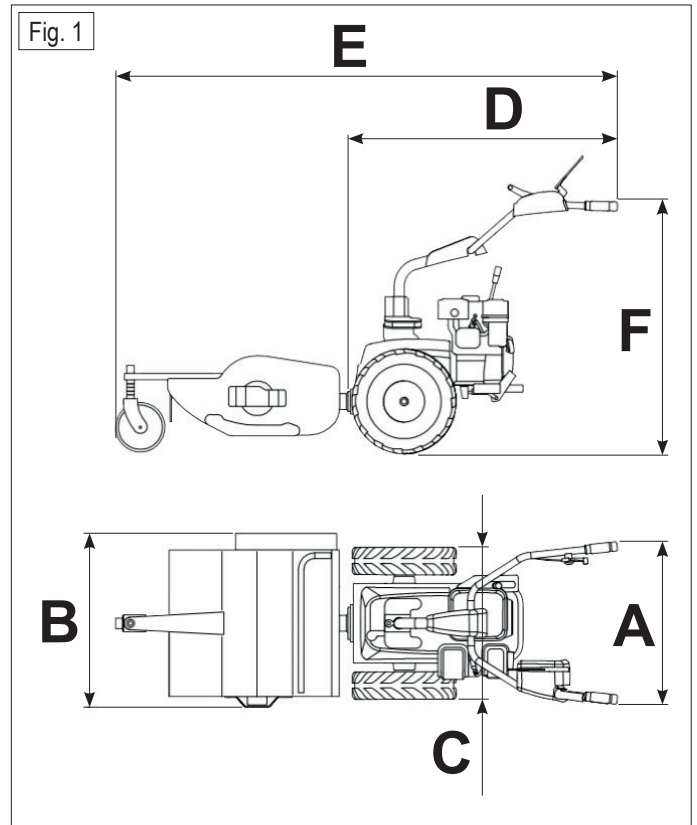

9. OPERATING INSTRUCTIONS - GH 8 AGM STANDARD CONFIGURATION WITH 58 CM FLAIL MOWER

9.1 SETTING UP THE MACHINE FOR USE

- Check the integrity of the machine to ensure that it has not been damaged during transport;
- Remove the machine from its packaging, taking care not to damage the levers and cables. Use an appropriate hoist with a minimum load capacity of 200 kg;
- Raise the handlebar to the driving position using the height adjustment lever (fig. 2/5);
- Now stabilise the machine body in a horizontal position by lowering the rod attached to the engine guard (fig. 2/9) and secure it by tightening the knob;
- Take the flail mower out of its packaging and fit it to the machine by fully tightening the fixing nuts (fig. 3);
- Check the tyre pressure (4.00-8 2PLY RATING) it must be 1.5 bar.

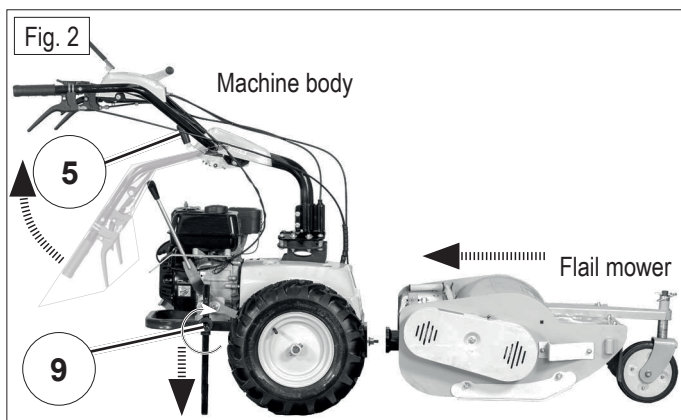

9.2 CHECKS TO BE CARRIED OUT BEFORE STARTING THE ENGINE

Before using the machine, always check that:

1. The engine oil is level (follow the appropriate booklet). There are two oil plugs, the photo (fig. 4) shows the one that is most accessible. For a detailed oil level check see chapter 13. Ordinary Maintenance;
2. The intake grids for engine cooling are clean (fig. 7/7);
3. The inside of the working frame is well cleaned (fig. 5);
4. All levers are in the neutral position;
5. The PTO is disengaged;
6. The air filter (oil-bath version, fig. 7/1) is clean and the oil is level;
7. There is sufficient fuel inside the tank; use a funnel with a very fine filter to fill the fuel tank.

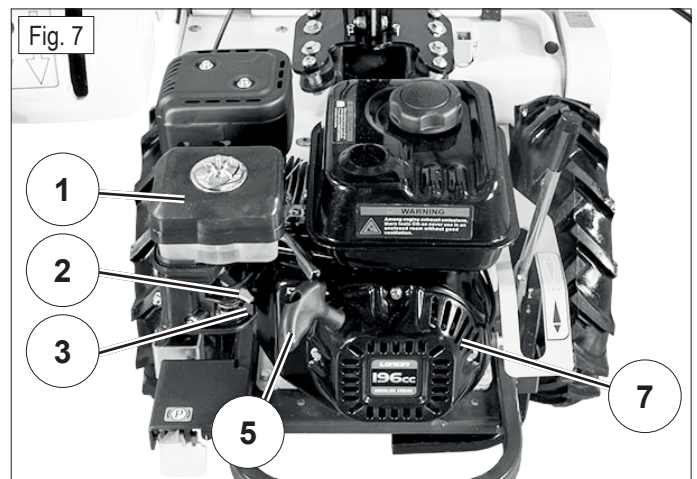
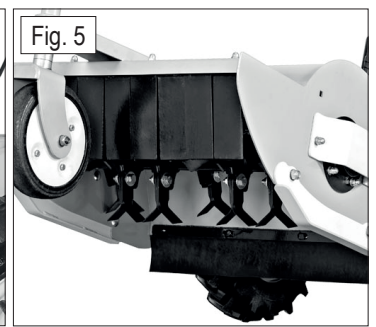
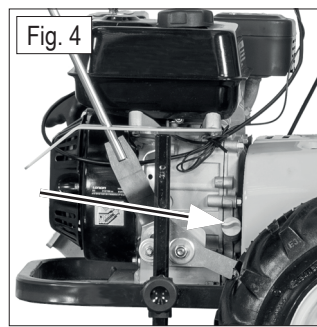

9.3 STARTING THE ENGINE

1. Open the fuel tap (fig. 7/3);
2. Set the throttle to the halfway position 1 (fig. 6/1) and if the engine is cold activate the choke (fig. 7/2);
3. Start the engine by firmly pulling the recoil starter knob (fig. 7/5);
4. Once the engine has started, move the choke lever (fig. 7/2) to the starting position.

9.4 STARTING THE MACHINE

⚠ CAUTION: before starting work, always wear appropriate work wear, gloves, safety shoes and goggles.

1. Adjust the handlebar height by releasing the handlebar lever under the central fairing (fig. 8/5);
2. To rotate the handlebar, press the lever on the left-hand side under the handlebar grip (fig. 8/1), rotate the handlebar to the right or left and then release the lever to lock the position. This adjustment can be useful when working, for example, close to a hedge or an edge with shrubs;
3. Set the height of the flail mower by removing the latch (fig. 9) and pulling out the wheel. The zinc plated bushes can be moved above or below the bushing (fig. 9/A and 9/B). The height ranges from a minimum of 2 cm (fig. 9/A) to a maximum of 11 cm (fig. 9/B).

⚠ CAUTION: the height adjustment of the flail mower must always be made with the engine switched off.

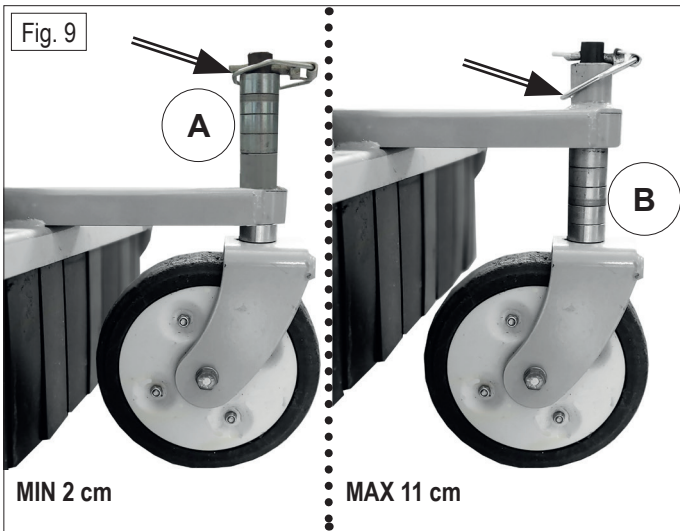
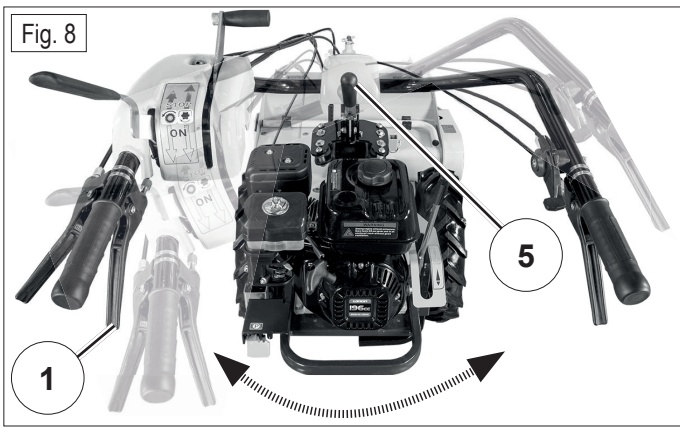

4. Now start the engine (see 9.3 Starting the Engine);
5. Set the speed control lever (fig. 10/8) in the STOP position;
6. Lower the forward lever (fig. 10/3) and gently operate the speed control lever (fig. 10/8). By pushing it forward, the machine will move forward and the speed will increase continuously as the lever moves forward (be very careful when handling this manoeuvre, you must become familiar with the lever). Reversing is achieved by pulling the speed control lever towards you;

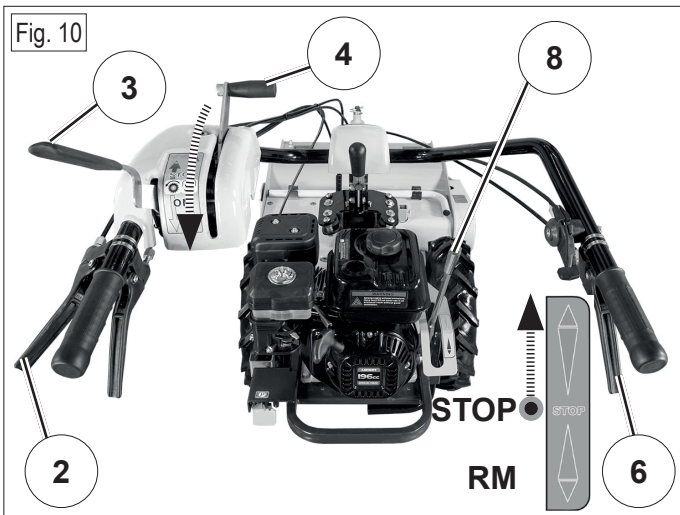

CAUTION: With the forward lever (fig. 10/3) pressed down, both forward and reverse travel can be managed via the speed control lever (fig. 10/8) without discontinuity. It is recommended to handle the movements of speed control lever gently and smoothly without sudden jerks.

7. Practice forward and reverse travel only to familiarise yourself with the machine;
8. Then familiarise yourself with steering manoeuvres to the right or left by operating the levers on the handlebars. As you move

forward, pressing the right turn lever (fig. 10/6) will disengage the right wheel and the machine will tend to turn right; pressing the left turn lever (fig. 10/2) will disengage the left wheel and the machine will tend to turn left;

CAUTION: by releasing the forward lever (fig. 10/3) the machine stops.

CAUTION: when the PTO lever (fig. 10/4) is pointing towards the front of the machine the PTO is disengaged and the attachment is stopped, when the lever is pointing towards the operator the PTO is engaged and the attachment rotates.

9. To operate the flail mower, the throttle lever must be in half-way position 1 (fig. 6/1) and the speed control lever (fig. 10/8) must be in STOP. Hold down the forward lever (fig. 10/3) with your left hand, engage the PTO lever (fig. 10/4) and the flail mower will start to run. Move the throttle to maximum speed, then use the speed control lever to select the appropriate speed and begin work.

CAUTION: by releasing the forward lever (fig. 10/3) the machine stops and the PTO lever (fig. 10/4) returns to the STOP position: this is a safety feature that allows the operator at any time to stop the machine completely.

CAUTION: when the engine is running, never put hands or feet in the cutting area. Maintain all guards to allow safe use of the machine.

9.5 WORK CONCLUSION

Once work is finished, stop the engine by releasing the forward lever (fig. 10/3) and turn the throttle to position 0 (fig. 6/0), then close the fuel tap (fig. 7/3).

CAUTION: never leave the machine unattended and/or within reach of children or people who have not read this manual or who have not received adequate instructions for the safe and proper use of the hydrostatic flail mower.

IMPORTANT: to move the machine when the engine is stopped, both left and right turn levers (fig. 10/2 and 10/6) must be pressed simultaneously as this disengages the drive.

9.6 ORDINARY MACHINE CLEANING

CAUTION: before starting any cleaning work, always wear suitable clothing and protective goggles.

CAUTION: when cleaning the cutting rotor, always ensure that the motor is switched off.

CAUTION: in order to reduce the risk of fire, it is important to keep the engine and muffler area well cleaned of dust and dry grass residues and to allow the engine to cool down before storing the machine in an enclosed area.

At the end of each job, proper cleaning ensures a long service life for the machine and prevents most common inconveniences.

The best way to clean the machine is with compressed air in the engine area and optionally water for the body parts and the flail mower area.

IMPORTANT: avoid wetting the engine linkages, cables and handlebar levers with a strong jet of water.

9.7 USEFUL RULES FOR CORRECT USE

The machine will work in optimum condition if certain precautions are followed.

- Before starting work, check that the attachment is clean, free of grass and dirt;
- Always keep cables and levers clean of dirt and dust;
- Before starting work, check the ground for stones, large branches and foreign bodies. If possible, remove them;
- Be careful if the engine revs drop: you are working overloaded, you must reduce the forward speed. Never force the engine: when smoke comes out of the exhaust it is overloaded, you must slow down;
- Never leave the machine under the rain;
- Check the knives of the flail mower frequently (fig. 5), ensure that they are free to rotate, if worn, turn them and replace them if necessary: the finish of the work will be better and the engine will absorb less power;
- During work keep the engine at maximum revs, adjust the speed according to the height of the grass to be shredded;
- Keep the engine grids clean (fig. 7/7);
- Check frequently the tyre pressure.

9.8 SLOPING TERRAIN

Be careful when working on slopes, the manoeuvrability of the machine is reduced.

⚠ CAUTION: avoid slopes that are too steep; for correct machine operation and safety, observe the slope limits of the engine: max 20°.

Steep terrain should be negotiated if possible in the uphill/downhill direction, taking great care when changing direction and that the uphill wheel does not encounter any obstacles (stones, branches, roots, etc.) that could cause the machine to tip over or lose control. Therefore, assess the various situations and be careful on wet ground and wet grass, as the machine could slip.

When going downhill, start at low speed.

⚠ CAUTION: on sloping terrain, avoid disengaging drive to the wheels by pressing both turn levers (fig. 10/2 and 10/6) at the same time as the machine will run away downhill without control.

10. SAFETY DEVICES

10.1 ACTIVE COUPLING

The machine is equipped with an active coupling system.

Releasing the forward lever (fig. 10/3) causes the machine to stop and the PTO lever (fig. 10/4) to return to the STOP position; this is a safety feature that allows the operator at any time to stop the attachment and the forward/reverse travel of the machine.

⚠ CAUTION: check frequently that the active coupling functions correctly. When the forward lever (fig. 10/3) is released, the machine must stop immediately.

10.2 STATIONARY BRAKE

To park the machine correctly, the pedal brake must be engaged.

In the position in fig. 11 the brake is disengaged, in the position in fig. 12 the brake is engaged.

Always apply the parking brake when leaving the machine on a slope or during transport.

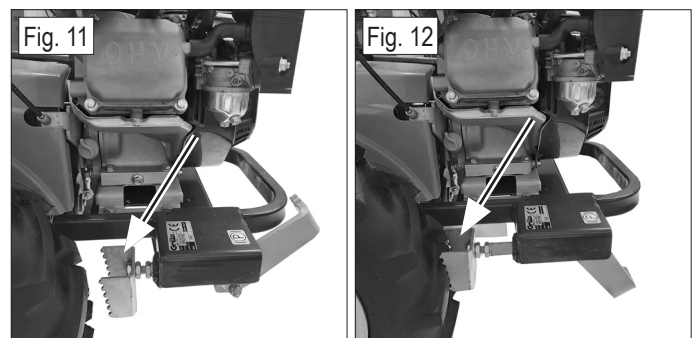

11. ORDINARY ADJUSTMENTS

11.1 HANDLEBAR SETTING

Before starting work, it is recommended to position the handlebar in the most comfortable position and with the greatest control over the machine. To adjust the height of the handlebar, push down the lever located at the base of the handlebar (fig. 13/5), then move the handlebar up or down. To lock the handlebar in the desired position, release the lever, ensuring that its central pin engages in the notch.



In certain cutting conditions, such as clearing edges, it may be useful to rotate the handlebar to the right or left. To rotate it, simply use the appropriate lever (fig. 14/1): by pressing it, the handlebar can rotate freely and it will be possible to move it to the right or left. By releasing the lever, the column will lock into the holes in the base.

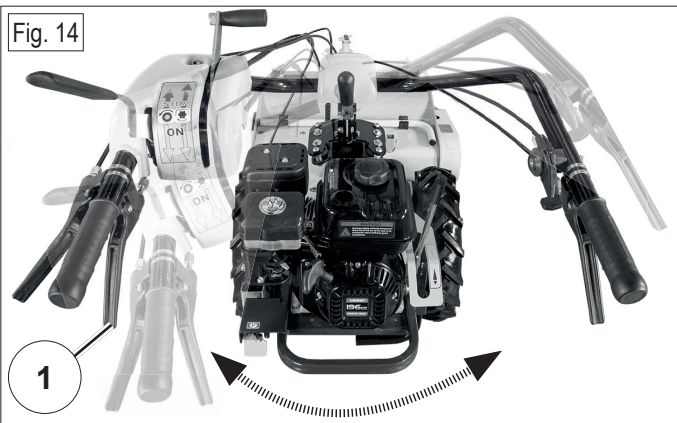

11.2 CUTTING HEIGHT ADJUSTMENT

In order to set the cutting height of the flail mower, it is necessary to remove the latch (fig. 15) and remove the wheel. The galvanised bushes can be moved above or below the bushing (fig. 15/A and 15/B). The height ranges from a minimum of 2 cm (fig. 15/A) to a maximum of 11 cm (fig. 15/B).

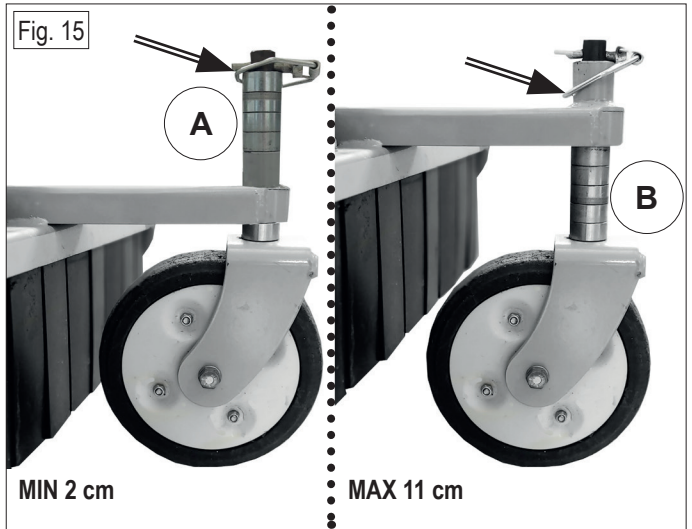

⚠ CAUTION: the height adjustment of the flail mower must always be made with the engine switched off.

12. EXTRAORDINARY ADJUSTMENTS

⚠ CAUTION: The adjustment procedures described below require technical skills and expertise. It is advisable to contact an authorised Grillo centre to carry them out.

Keeping the levers at the correct tension ensures proper operation of the machine controls. The tension of the connected cable can be adjusted for each lever.

Before any adjustment, carry out a visual check of the machine.

12.1 ADJUSTING THE TURN LEVERS

When pressing the right turn lever (fig. 16/6) the right-hand wheel should disengage from the transmission; if this does not happen, loosen the lock nut (fig. 17/B) and slightly extend the adjuster (unscrew it), then retighten the lock nut.

In the same way the left turn lever (fig. 16/2) can be adjusted with the left turn lever adjuster (fig. 17/A).

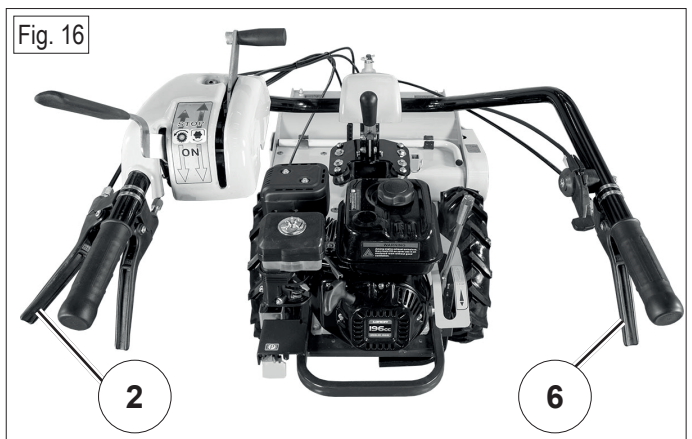

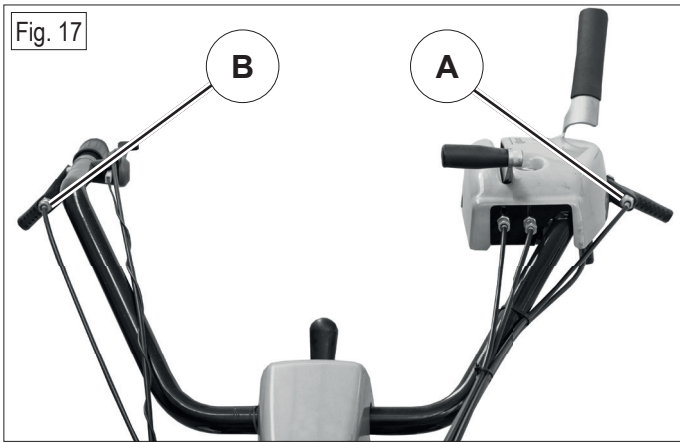

12.4 ADJUSTING THE HANDLEBAR ROTATION LEVER

If the pin that locks the handlebar is not released when the handlebar rotation lever (fig. 20/1) is pressed, it is necessary to loosen the lock nut (fig. 20/E) and slightly extend the adjuster (unscrew it), then retighten the lock nut.



12.2 ADJUSTING THE FORWARD LEVER

If the machine does not move when the forward lever (fig. 18/3) is lowered, it is necessary to loosen the lock nut (fig. 18/C) and slightly extend the adjuster (unscrew it), then retighten the lock nut. If, on the other hand, the machine moves despite the forward lever being lifted, it is necessary to loosen the lock nut and shorten the adjuster slightly (screw it in), then retighten the lock nut.

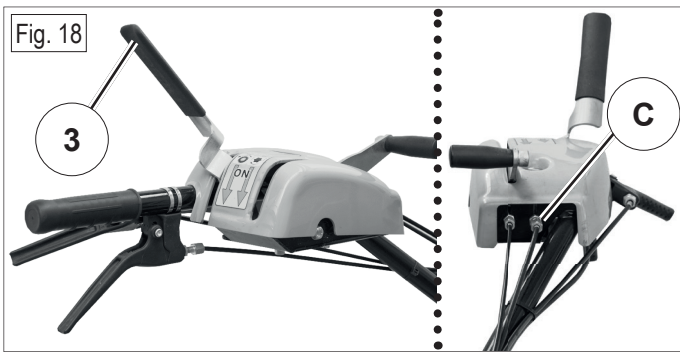

12.5 ADJUSTING THE FLAIL MOWER BELT TENSION

Regularly check the belt tension of the side drive belt of the flail mower (every 10 hours).

To do this, remove the side cover of the flail mower (fig. 21).

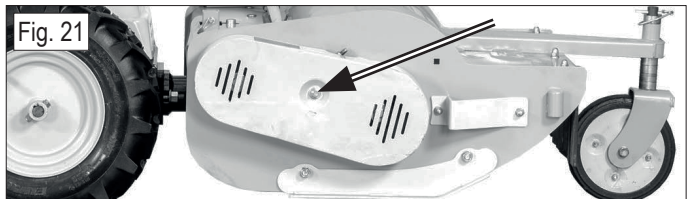

12.3 ADJUSTING THE PTO LEVER

If the flail rotor does not start when the PTO lever (fig. 19/4) is operated, it is necessary to loosen the lock nut (fig. 19/D) and slightly extend the adjuster (unscrew it), then retighten the lock nut.

If, on the other hand, the flail rotor does start despite the PTO lever being released, it is necessary to loosen the lock nut and slightly shorten the adjuster (screw it in), then retighten the lock nut.

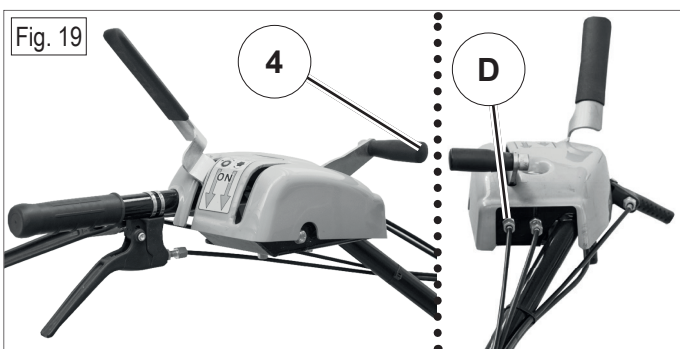

For correct belt tension, the red arrow tip (fig. 22/F) must be aligned with the washer under the tightening nut; if the arrow is not in the correct position, it is necessary to loosen the lock nut (fig. 22/G) and screw or unscrew the tightening nut (fig. 22/H) until the arrow tip is in the correct position, then retighten the lock nut.

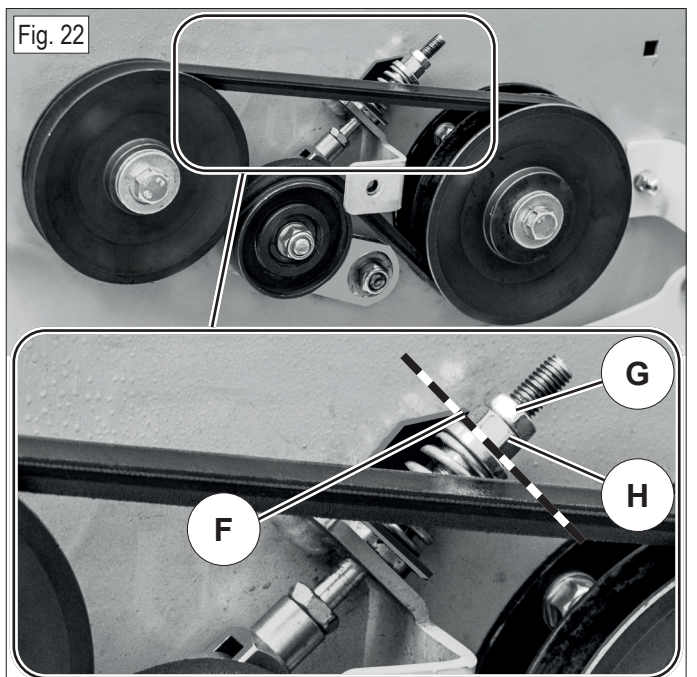

13. ORDINARY MAINTENANCE

⚠ CAUTION: always use suitable tools such as supports and safety devices if the machine or part of it has to be lifted.

- Always wear suitable clothing and work gloves before starting any cleaning, maintenance or repair work;
- Do not leave the machine during maintenance without safety devices or lifted, in places accessible to inexperienced people, especially children;
- Never dispose of used oil, fuel and any other pollutants into the environment!
- Regular maintenance helps to keep the machine in perfect working order.

⚠ CAUTION: before carrying out all control and maintenance operation, make sure that the engine is switched off.

13.1 ENGINE MAINTENANCE

🔧 IMPORTANT: read the engine manual; check the engine periodically, keep the air filter clean and the engine oil level.

🔧 IMPORTANT: place the machine in a horizontal position to check fluid levels.



ENGINE AIR FILTER

Check and clean the air filter every 10 hours.
For engines with an oil-bath air filter (fig. 7/1), change the oil if dirty. Use the engine oil recommended in the engine manual.

ENGINE OIL

🔧 IMPORTANT: it is essential to change the engine oil after the break-in period (first 20 hours). Then change the oil every 100 hours or once a year.

The engine must be cold and in a horizontal position to check the engine oil level.

Remove the filling plug/dipstick and clean it (fig. 23).

Reinsert and remove the dipstick without screwing it into the filler neck: the oil level will be marked on the dipstick.

If the oil level is low, top up to the edge of the filler neck with the recommended oil; see the engine manual for further instructions.

To change the engine oil, follow the instructions in the engine manual.

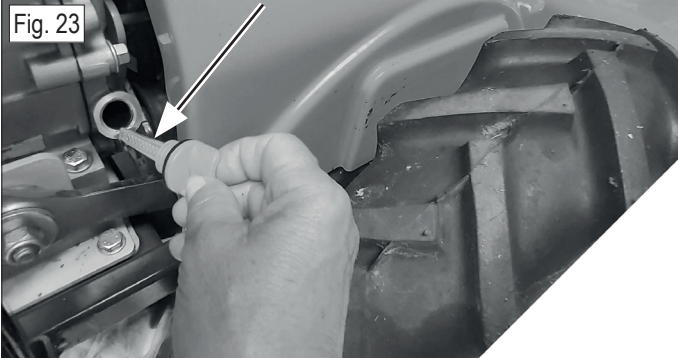

13.2 MAINTENANCE OF THE FLAIL MOWER

MAINTENANCE POSITION OF THE FLAIL MOWER

It is possible to service the flail mower by raising it and keeping it in a stable position by placing the lifting support rod in the appropriate holder.

⚠ CAUTION: all maintenance work on the flail mower must be carried out with the engine switched off and the parking brake applied.



LUBRICATING THE TRANSMISSION

Remove the upper metal protection by unscrewing the 4 screws that secure it (fig. 25). Change the transmission oil every 50 working hours. Use IP MELLANA 220 gearbox oil, quantity: 0.2 litres.

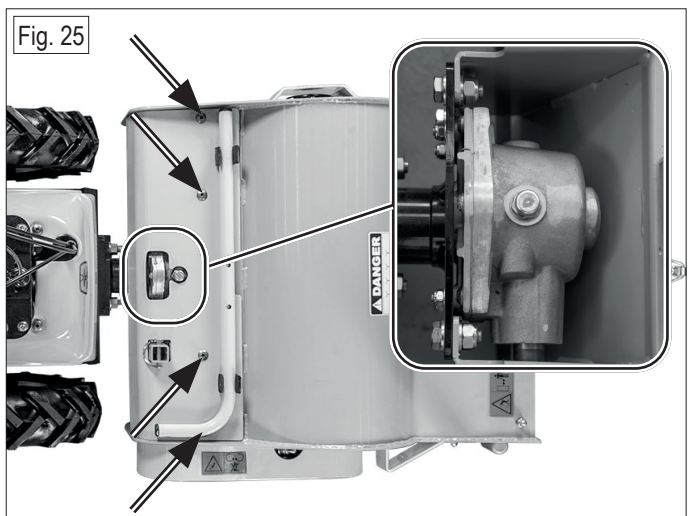

GREASING THE ROTOR BEARINGS

Grease the roller bearings every 20 operating hours, using the grease nipples (fig. 26).

Fig. 26

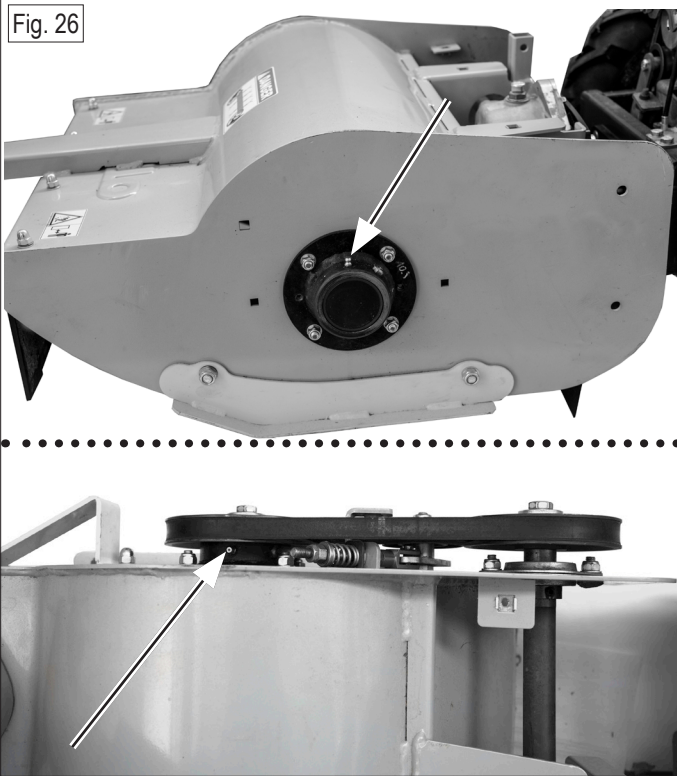

Fig. 27

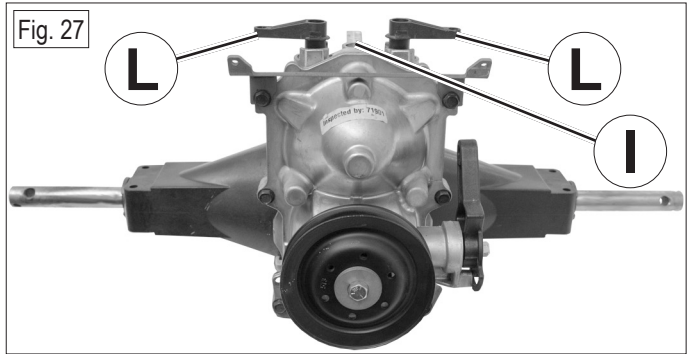

Fig. 28

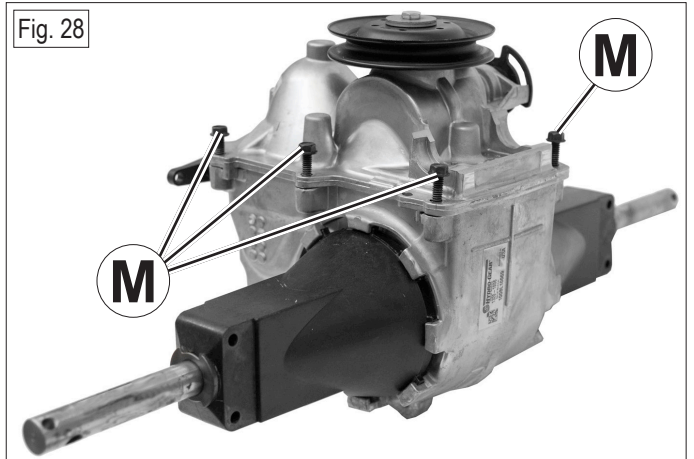
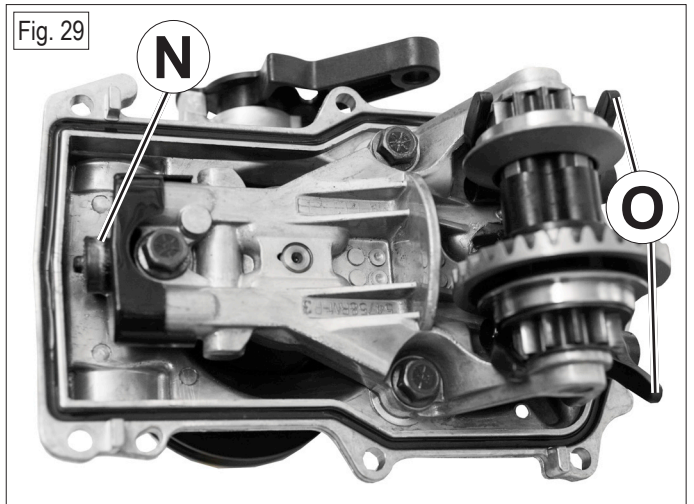

Fig. 29



14. EXTRAORDINARY MAINTENANCE

⚠ CAUTION: the adjustment procedures described below require technical skills and expertise. It is advisable to contact an authorised Grillo centre to undertake these procedures.

14.1 MAINTENANCE OF THE HYDROSTATIC AXLE

The hydraulic axle oil does not need to be changed. Should it be necessary to open the transmission, follow the procedure described below.

1. Remove the axle from the machine;
2. Unscrew the plug (fig. 27/I);
3. Raise the levers (fig. 27/L) by 2 cm, using a thin screwdriver to release the locking tabs;
4. Drain all the oil;
5. Clamp the axle in a vice;
6. Undo the six bolts (fig. 28/M) and open the axle;
7. Thoroughly clean the magnet (fig. 29/N) and the housing of any metal residue;
8. Reassemble the axle, taking care to reposition all parts correctly;
9. Close the cover, taking care to correctly reinsert the two plastic pins into the holes in the plastic forks (fig. 29/O);
10. Tighten all cover bolts (fig. 28/M);
11. Keep the levers (fig. 27/L) lifted up;
12. Fill the axle with 1.8 L of oil Grillo code 53140 or gearbox oil 10W60;
13. Lower the levers (fig. 27/L) until they click into place and tighten the oil plug (fig. 27/I).

⚠ CAUTION: replacement of the belts below should only be carried out if the belts are excessively worn, broken or have evident cracks.

14.2 REPLACING THE HYDROSTATIC AXLE BELT

To replace the hydrostatic axle belt, it is necessary to contact an authorised Grillo centre.

14.3 REPLACING THE PTO BELTS

To replace the PTO belts, it is necessary to contact an authorised Grillo centre.

14.4 REPLACING THE FLAIL MOWER DRIVE BELT

To replace the flail mower drive belt, it is necessary to:

1. To replace the flail mower drive belt, it is necessary to:
2. Remove the guard located on the right side of the flail mower (fig. 21);
3. Loosen the tensioner by unscrewing the nuts located above the tie rod (fig. 32);
4. Replace the worn belt with a new original Grillo belt;
5. Adjust the tension of the tensioner (see chapter 12.5 Adjusting the flail mower belt tension);
6. Refit the guard on the right side of the flail mower.



15. TROUBLESHOOTING GUIDE

GH 8 AGM WITH FLAIL MOWER - TROUBLESHOOTING GUIDE		
PROBLEM	CAUSE	SOLUTION
The engine does not start	Out of fuel	- Check that the fuel tap is open - Check the fuel level
	Throttle is set to zero	- Move the throttle to position 1
	Combustion issues	- Check that the choke is applied (if the engine is cold) - Check that the hole in the tank cap is not blocked - Check that the carburettor jets are clean - Check that the spark plug gives a spark
The engine starts but the machine does not move forward	The speed control lever is in the neutral position	- Move the lever forward or backward to select the desired speed
	Insufficient cable tension of the forward lever	- Act on the forward lever adjuster, increasing the tension of the connected cable (see chapter 12.2)
The machine moves forward even if the forward lever is not pressed	Excessive cable tension on the forward lever	- Act on the forward lever adjuster, decreasing the tension of the connected cable (see chapter 12.2)
The engine starts but the flail mower does not operate	Insufficient cable tension of the PTO lever	- Act on the PTO lever adjuster, increasing the tension of the connected cable (see chapter 12.3)
	Flail mower drive belt tension	- Adjust the flail mower belt tension (see chapter 12.5)
The engine does not switch off	Throttle not in zero position	- Move the throttle to the zero position
	Throttle not properly connected to the engine	- Check the throttle and its connection to the engine
Drop in engine performance during cutting	Overload	- Proceed with cutting small areas, avoiding cutting in areas with many residual shrubs - Raise the cutting height
The PTO engages even if the PTO lever is in the STOP position	Excessive cable tension of the PTO lever	- Act on the PTO lever adjuster, decreasing the tension of the connected cable (see chapter 12.3)
The engine switches off when activating the flail mower	Insufficient engine power output	- Increase power from the throttle
	Rotor jammed by an obstruction or wound grass	- Check for obstructions blocking the flail mower and remove them

⚠ CAUTION: If problems persist after carrying out the actions described in this manual, contact the authorised service centre. Never attempt to carry out major repairs without having the necessary means and technical expertise.

IF YOU HIT A STONE OR ANOTHER FOREIGN BODY

1. Disengage the cutting rotor;
2. Switch off the engine;
3. Pull out the lifting support rod;
4. Tilt the machine, raising the cutting rotor;
5. Insert the lifting support rod into the appropriate holder;
6. Check the integrity of the rotor and blades.

16. MAINTENANCE SCHEDULE

GH 8 AGM WITH FLAIL MOWER - MAINTENANCE SCHEDULE					
MAINTENANCE ITEM		AT EVERY USE	WHICHEVER OCCURS FIRST		
			FIRST 20 HOURS OR WITHIN THE FIRST MONTH	EVERY 50 HOURS OR 6 MONTHS	EVERY 100 HOURS OR EVERY YEAR
Engine oil	Check the level	●			
	Change		●		●
Air filter	Check	●			
	Replace				*
Flail mower transmission oil	Change			●	
Flail mower drive belt	Check the tension	●			
	Replace			●	
Check that the engine intake grid is well cleaned		●			
Checking the sharpness and fixing of the knives		●			
Grease lubrication			●	●	
Check tyre pressure (1.5 bar)			●	●	

● recommended task

* task to be carried out if necessary



IMPORTANT: regularly check the hydrostatic axle and the flail mower drive for oil leaks.

17. LUBRICATION CHART

GH 8 AGM WITH FLAIL MOWER - LUBRICATION CHART			
Engine oil	See engine manual	0,6 L	Change after the first 20 operating hours and then every 100 hours or once a year thereafter
Flail mower transmission oil	IP MELLANA 220	0,2 L	Change every 50 working hours or every 6 months
Hydrostatic axle oil	GRILLO 53140 10W60	1,8 L	Change when needed

18. STORAGE AND PROLONGED INACTIVITY

Store the machine in a dry place and protected from the elements. Clean the machine of dirt and grass residues and if possible cover it with a tarpaulin when the engine is cold. If the machine is not to be used for an extended period of time (more than 1 month) drain the fuel.

19. AVAILABLE ATTACHMENTS

On the GH 8 AGM machine it is possible to fit other attachments in addition to the 58 cm flail mower, as the hydrostatic transmission guarantees good operation.

The attachments available are:

68 CM ALL PURPOSE FLAIL MOWER

It is a wider flail mower with a higher cutting capacity, with 16 pairs of Y-shaped knives, two solid anti-puncture front wheels, crank-operated progressive cutting height adjustment.

Fig. 33



132 CM PRO DOUBLE BLADE CUTTER BAR

Professional-type cutter bar with oil-bath movement and elastic, self-adjusting blade tensioners (Busatis Austria System).

It is centrally controlled and its high output makes it ideal for cutting plots of land where the purchase of a sickle bar (which would remain unused for a large part of the year) is not justified, whereas the GH 8 AGM can be used with other attachments. The bar is fitted to the PTO instead of the flail mower.

Because of the elastic, self-adjusting blade tensioners, the operator does not have to make any manual adjustments as the contact force between blades is kept constant.

Fig. 34



100 CM ORIENTABLE SWEEPER

The sweeper is attached to the PTO of the machine.

It is very useful for cleaning concrete surfaces, driveways, yards; it is also suitable for clearing fresh snow up to a height of 10/12 cm.

The sweeper can be tilted to the right and left to form swaths.

Fig. 35

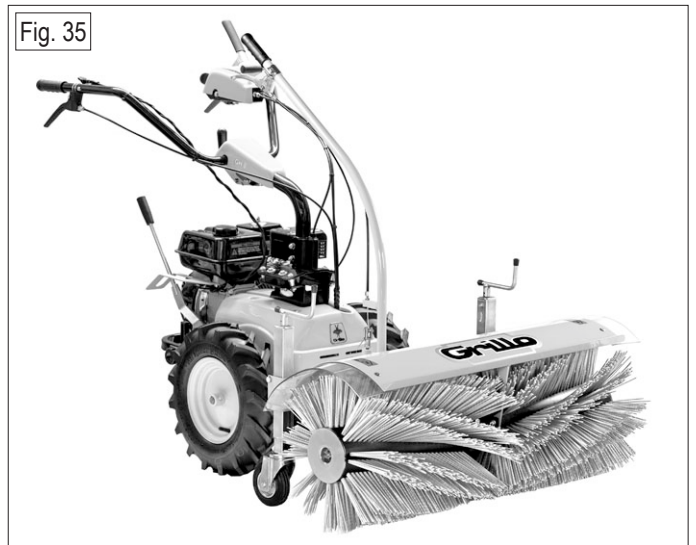

100 CM ORIENTABLE BLADE

The blade is equipped with a quick coupling and adapter sleeve.

Its sturdiness makes it ideal for clearing snow and levelling heaps of soil; it can be tilted to the right and left.

Fig. 36

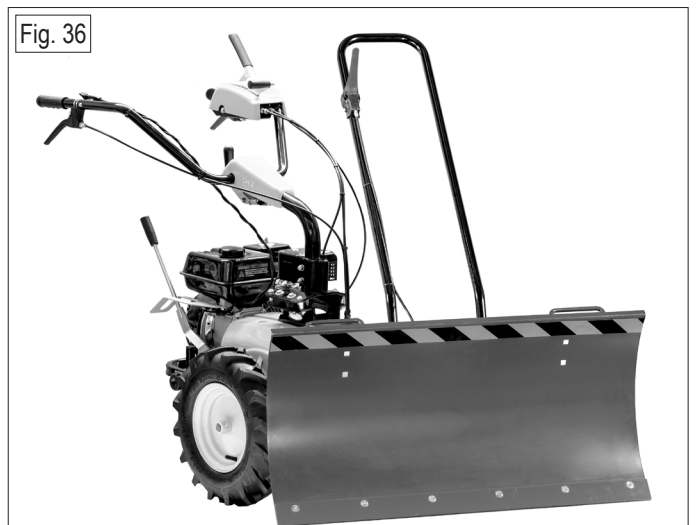

20. TECHNICAL ASSISTANCE SERVICE

20.1 ASSISTANCE

This manual provides instructions for the use of the machine and for its routine maintenance.

For extraordinary maintenance, for all operations requiring technical skills and expertise, please contact your authorised Grillo dealer.

20.2 IDENTIFICATION DATA

If it is necessary to contact an authorised service centre, for maintenance information, always provide:

machine model

serial number

The machine's serial number plate is located on the left-hand side of the frame (fig. 37).

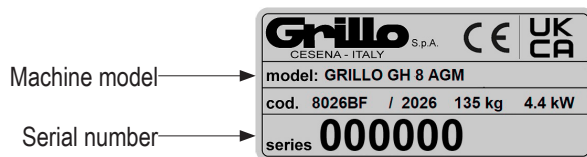

We advise the customer to note down this additional information in the spaces below. It may be useful for the service department.

PURCHASE DATE

GRILLO DEALER

20.3 SPARE PARTS

It is recommended to use only genuine spare parts to ensure product safety and durability.

20.4 WARRANTY

The warranty is provided in the manner and within the limits specified by current law. The retailer must hand over the machine's warranty certificate to the end customer, printing a copy of the registration from the Grillo website. Transport, servicing and wear parts remain at customer's expense. Any tampering or improper use not specifically authorised by Grillo will invalidate the warranty.

The engine follows the conditions specified by its manufacturer.

20.5 HOW TO ORDER SPARE PARTS

Contact our authorised centres.

Please indicate the serial number of the machine and the code of the component to be replaced.

It is possible to identify the part number by consulting the Grillo website: the spare parts tables of the machine will be available by entering the serial number.

21. TRANSPORT WARNINGS

⚠ CAUTION: make sure the engine is switched off.

LIFTING AND TRANSPORT

The GH 8 AGM may not be driven on public roads. If the machine is loaded onto a transport vehicle, secure it properly with ropes and lower the handlebar if necessary. When lifting, ensure that cranes, hoists and ropes have sufficient lifting capacity for the weight of the machine.

22. DISPOSAL

Waste products such as waste oil or fuel, used lubricants, filters, or other such consumable parts can cause harm to people, animals and the environment. They must therefore be disposed of properly. Contact a recycling centre or your retailer for information on correct disposal.



Grillo S.p.A. Via Cervese 1701- 47521 Cesena (FC)- Italy
www.grillospa.it - E-mail: grillo@grillospa.it



**DECLARATION OF CONFORMITY / DICHIARAZIONE DI CONFORMITÀ
/ DÉCLARATION DE CONFORMITÉ / KONFORMITÄTSEKRLÄRUNG / DECLARACIÓN DE CONFORMIDAD**

The undersigned / lo sottoscritto / Je soussigné / Der Unterzeichner / Yo suscrito

Ing. Andrea Pinza

as legal representative of: / in qualità di legale rappresentante della ditta: / en qualité de représentant légal de la société: / als rechtlicher Vertreter der Firma: / en calidad de representante legal de la empresa:

GRILLO SPA – Via Cervese, 1701 – 47521 CESENA (FC) – ITALY

declare that the following machinery: / dichiaro che la macchina di seguito indicata: / déclare que la machine suivante: / Hiermit erkläre ich, dass folgende Maschine: / declara que la siguiente máquina:

Model Modello Modèle Modell Modelo	Function Funzione Dénomination Bezeichnung Función	From serial number Dal numero di serie Du numéro de série Ab Seriennummer Desde número de serie
GH 8 AGM	Hydrostatic walk behind brush cutter / Trinciaerba idrostatico / Faucheuse- broyeuse hydrostatique / Hydrostatischer Wiesenmäher / Desbrozadora hidrostática	771474

fulfils all the relevant provisions of the following directives: / è conforme a tutte le disposizioni pertinenti delle seguenti direttive: / satisfait à l'ensemble des dispositions pertinentes des directives suivantes: / allen einschlägigen Bestimmungen folgender Richtlinien entspricht: / cumple todas las disposiciones pertinentes de las siguientes directivas:

CE	
2006/42/CE 2000/14/CE 2014/30/UE	UNI EN 12733

UK CA	
S.I. 2008 No. 1597	EN 12733

Juridical person authorised to compile the technical file: / Persona giuridica autorizzata a costituire il fascicolo tecnico: / Personne morale autorisée à constituer le dossier technique: / Juristische Person, die bevollmächtigt ist, die technischen Unterlagen zu erstellen: / Persona jurídica facultada para elaborar el expediente técnico:

GRILLO SPA – Via Cervese, 1701 – 47521 CESENA (FC) – ITALY

Person empowered to draw up the declaration on behalf of the manufacturer: / Persona autorizzata a redigere la dichiarazione a nome del fabbricante: / Personne ayant reçu pouvoir pour rédiger cette déclaration au nom du fabricant: / Ermächtigte Person zur Ausfertigung der Erklärung im Namen des Herstellers: / Persona apoderada para redactar esta declaración en nombre del fabricante:

Ing. Andrea Pinza

GRILLO SPA – Via Cervese, 1701 – 47521 CESENA (FC) – ITALY

Managing Director / Amministratore Delegato / Directeur Général / Stellvertretender Geschäftsführer / Director Adjunto

Grillo S.p.A.

Ing. Andrea Pinza -

Cesena, 26/02/2026

Sound power level / Potenza sonora / Niveaux sonores / Schallleistung / Potencia acústica

Model Modello Modèle Modell Modelo	Guaranteed sound power level Potenza sonora garantita Puissance sonore garantie Garantierte Schallleistung Potencia acústica garantizada
GH 8 AGM	95 dBA

Measure sound pressure at the operator's ear / Pressione sonora misurata all'orecchio dell'operatore / Niveaux sonores au niveau des oreilles de l'utilisateur / Gemessener Schalldruck am Ohr des Nutzers / Presión acústica medida a la oreja del usuario

Model Modello Modèle Modell Modelo	Sound pressure Pressione sonora Niveau sonore Schalldruck Presión acústica
GH 8 AGM	85 dBA

Vibrations / Vibrazioni / Vibrations / Schwingungen / Vibraciones

Model Modello Modèle Modell Modelo	Left hand/arm Mano/braccio sinistro Main/bras gauche Hand/Arm links Mano/Brazo izquierdo	Right hand/arm Mano/braccio destro Main/bras droit Hand/Arm rechts Mano/brazo derecho	Uncertainty Incertezza Incertitude Unsicherheit Incertidumbre
GH 8 AGM	14.41 m/s ²	7.62 m/s ²	0.04 m/s ²

The spare parts catalogues are available on line at http://www.grilloagrigarden.co.uk/spare_parts_lists
Le tavole ricambi sono disponibili online all'indirizzo http://www.grillospa.it/tavole_ricambi
Les vues éclatées son disponibles en ligne sur http://www.grillofrance.fr/vues_eclatees
Die Ersatzteillisten sind online verfügbar unter <http://www.grillodeutschland.de/ersatzteillisten>
Los despieces son disponibles on line en <http://es.grillospa.it/despieces>

Grillo S.p.A.

VIA CERVESE 1701 - 47521 CESENA - ITALIA
Tel: (+ 39) 0547633111
Website: www.grillospa.it
E-mail: grillo@grillospa.it

Grillo Agrigarden Ltd

DOVE FIELDS UTTOEXETER - ST148HU STAFFORDSHIRE - UNITED KINGDOM
Tel: (+ 44) 01889569149
Website: www.grilloagrigarden.co.uk
E-mail: info@grilloagrigarden.co.uk

Grillo Australasia Pty Ltd

14 REBECCA COURT - VIC 3943 SORRENTO - AUSTRALIA
Tel: (+ 61) 0428206225
Website: www.grilloaustralia.com.au
E-mail: allan@grilloaustralia.com.au

Grillo Deutschland GmbH

GUNTERSRIETHER STR.14 - 91224 HARTMANNSHOF - DEUTSCHLAND
Tel: (+ 49) 09154949216
Webseite: www.grillodeutschland.de
E-Mail: grillo@grillodeutschland.de



Grillo
AGRIGARDEN MACHINES